

NEW ITEMS // April 2024

Chrome Tail Light Bezel With Black Painted Detail

1964.5-1966 Ford Mustang

- Enhanced triple chrome plating process for a high-quality chrome finish
- Superior die-cast quality for exceptional durability
- Designed to match the original in shape and size, ensuring a hassle-free installation

F6405 | Chrome Tail Light Bezel

| 1 Pc. / Each

NEW & IMPROVED!

CHROME FINISH

EASY INSTALLATION

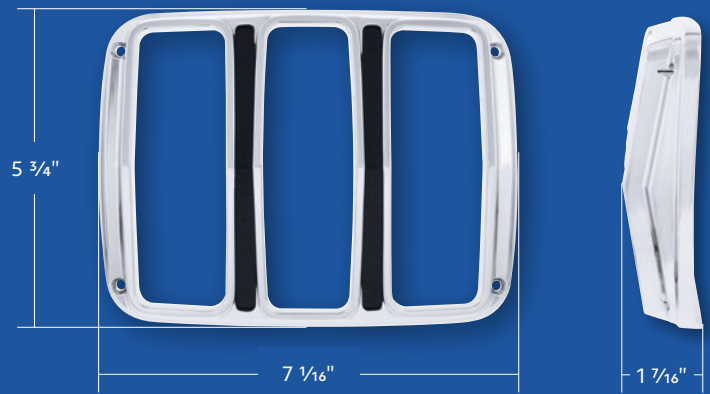
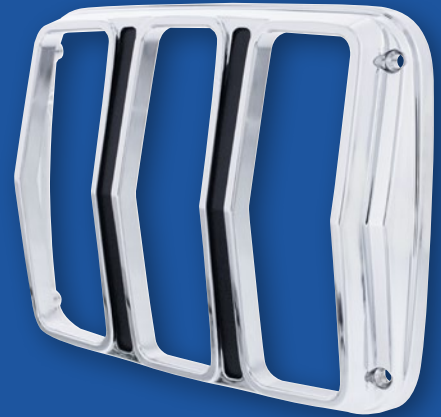

RECOMMENDED ITEMS

LED Tail Lights

1964.5-1966 Ford Mustang

- Super bright red LED with high quality injection molded polycarbonate lens
- Epoxy coated, fully sealed electronics
- Easy electrical connection with 1157 plug, no modification to vehicle
- Energy efficient solid-state circuit board engineered for 12V DC systems
- LED compatible flasher required for proper operation, item #90652 and 90649

110105

Sequential Tail Light

| 1 Pc. / Card

FTL6401LED

Tail Light

| 1 Pc. / Card

68 LEDs

EASY PLUG-IN



#110105

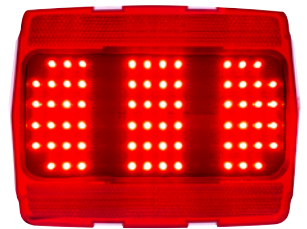

#FTL6401LED



T 866.327.5288 | F 888.986.6088 | classic.upauto.com

BACK IN STOCK

Window Regulator

1951-1955 Chevrolet & GMC Truck

- High strength steel stamping
- Includes counter balance spring
- Zinc plated finish for better corrosion resistance

116512 | Right Hand
116511 | Left Hand

1 Pc. / Each
1 Pc. / Each

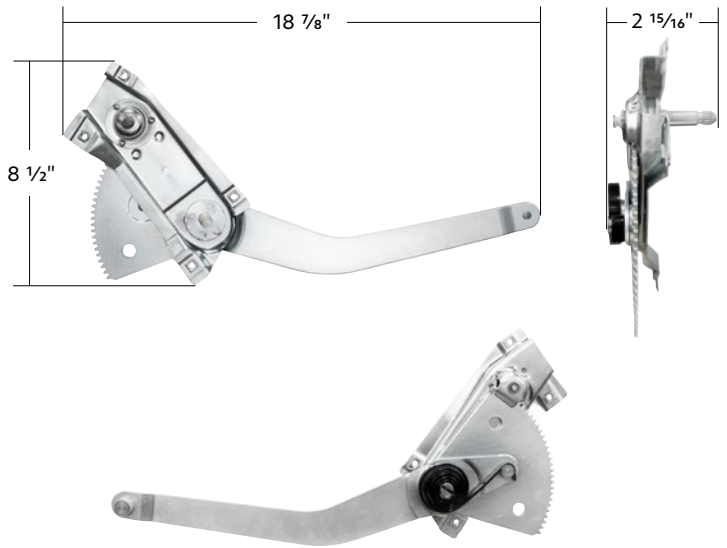

NEW & IMPROVED!

Blue Tiger Elevate Ultra 2.0 Bluetooth Headset

- New Bluetooth 5.2 allows longer range and faster transfer speed for quicker connection between two devices
- New optional cool gel ear cushion included for long term comfort
- New USB C allows for quicker charging, full charge in 1.5 hours
- Advanced noise-canceling for crystal-clear sound and word clarity
- Made for hard working truckers, offering battery life for longest talk time, best comfort, and premium sound
- Seamlessly connect your preferred virtual assistant to your mobile devices
- 60 hours battery life (talk time), 1200 hours of standby time
- 96% noise cancellation
- Supports English, French, and Spanish languages
- In the box: Elevate Headset, USB C charging cable, D/C vehicle adapter, perforated cooling gel ear cushion, bonus protein leather ear cushion, bonus mic cover, bonus headset bag, & quick start guide

95003 | Black

1 Pc. / Cbox

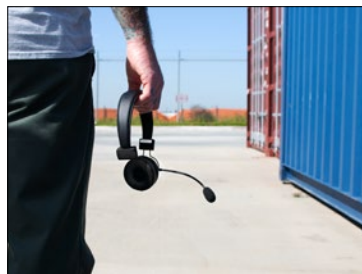

WELCOME TO YOUR
ALL-IN-ONE DEALER PORTAL
 ONE-STOP ONLINE BUYING EXPERIENCE.

CONTACT US TO SIGN UP TODAY!

T 866.327.5288
 F 888.986.6088
classic.upauto.com