

**NEW ITEMS // April 2024**

## Chrome Tail Light Bezel With Black Painted Detail

**1964.5-1966 Ford Mustang**

- Enhanced triple chrome plating process for a high-quality chrome finish
- Superior die-cast quality for exceptional durability
- Designed to match the original in shape and size, ensuring a hassle-free installation

**F6405** | Chrome Tail Light Bezel

| 1 Pc. / Each

**NEW & IMPROVED!**

**CHROME FINISH**

**EASY INSTALLATION**

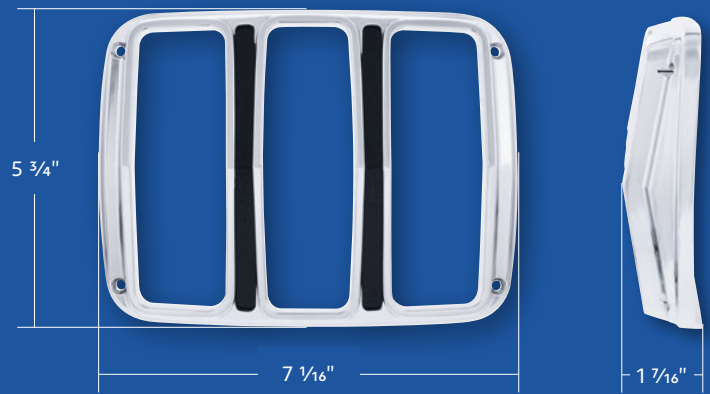
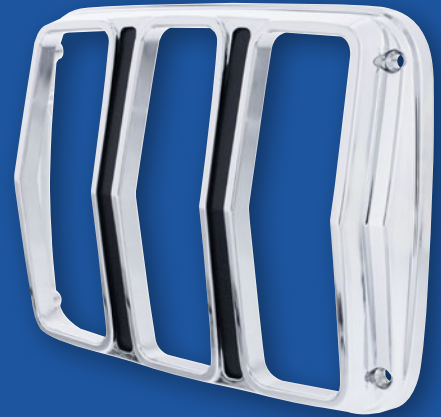

## RECOMMENDED ITEMS

### LED Tail Lights

**1964.5-1966 Ford Mustang**

- Super bright red LED with high quality injection molded polycarbonate lens
- Epoxy coated, fully sealed electronics
- Easy electrical connection with 1157 plug, no modification to vehicle
- Energy efficient solid-state circuit board engineered for 12V DC systems
- LED compatible flasher required for proper operation, item #90652 and 90649

**110105**

Sequential Tail Light

| 1 Pc. / Card

**FTL6401LED**

Tail Light

| 1 Pc. / Card

**68 LEDs**

**EASY PLUG-IN**



**#110105**

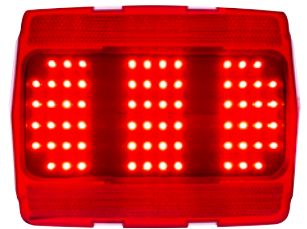

**#FTL6401LED**



T 866.327.5288 | F 888.986.6088 | [classic.upauto.com](http://classic.upauto.com)

**BACK IN STOCK**

## Window Regulator

**1951-1955 Chevrolet & GMC Truck**

- High strength steel stamping
- Includes counter balance spring
- Zinc plated finish for better corrosion resistance

**116512** | Right Hand  
**116511** | Left Hand

**1 Pc. / Each**  
**1 Pc. / Each**

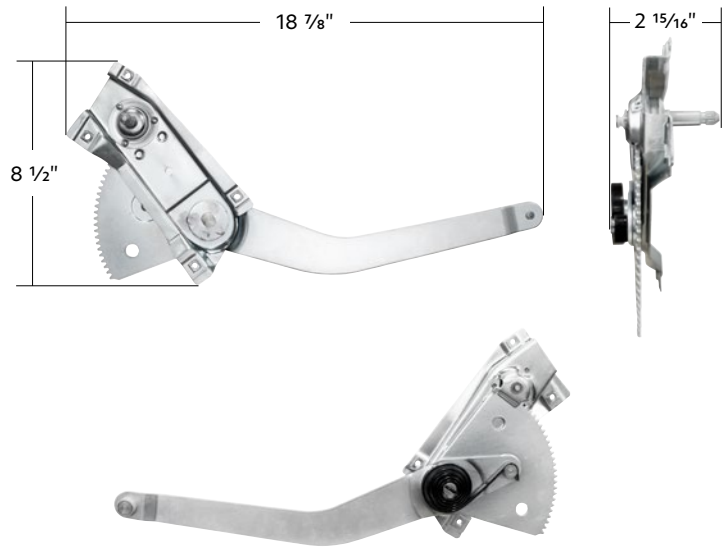

**NEW & IMPROVED!**

## Blue Tiger Elevate Ultra 2.0 Bluetooth Headset

- New Bluetooth 5.2 allows longer range and faster transfer speed for quicker connection between two devices
- New optional cool gel ear cushion included for long term comfort
- New USB C allows for quicker charging, full charge in 1.5 hours
- Advanced noise-canceling for crystal-clear sound and word clarity
- Made for hard working truckers, offering battery life for longest talk time, best comfort, and premium sound
- Seamlessly connect your preferred virtual assistant to your mobile devices
- 60 hours battery life (talk time), 1200 hours of standby time
- 96% noise cancellation
- Supports English, French, and Spanish languages
- In the box: Elevate Headset, USB C charging cable, D/C vehicle adapter, perforated cooling gel ear cushion, bonus protein leather ear cushion, bonus mic cover, bonus headset bag, & quick start guide

**95003** | Black

**1 Pc. / Cbox**

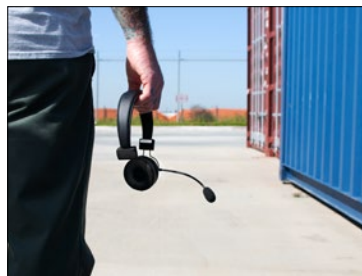

WELCOME TO YOUR  
**ALL-IN-ONE DEALER PORTAL**  
ONE-STOP ONLINE BUYING EXPERIENCE.

**CONTACT US TO SIGN UP TODAY!**

T 866.327.5288  
F 888.986.6088  
[classic.upauto.com](http://classic.upauto.com)